

# 6228



MODEL 6228

## SOFT SERVE FREEZER

Single flavor, Countertop, Gravity feed, Microprocessor control

### Product Offering

Offer all popular soft serve variations from low or non-fat ice cream to custards, yogurt and sorbet

### Freezing Cylinder

One, 1.7 Liter (1.8 quarts)

### Mix Hopper

One, 12 Liters (12.68 quarts)

Separate hopper refrigeration maintains mix temperature below 4.4°C (40°F) during Cool and Standby modes.

### Mix Low Indicator

When mix level is low, the Mix Low light turns "ON" to alert operator to add mix.

### Standby

Maintains product temperature in the mix hoppers and freezing cylinders below 4.4°C (40°F) during long no-use periods.

### Microprocessor Controls

Automatically regulates refrigeration and maintains consistent product quality by controlling product temperature and viscosity.

### Counter

Records number of dispenses per day and total number of dispenses.

### Temperature Display

Displays hopper and cylinder temperature; helps control product safety

### Output

300 Cups/Hour  
(80 gram/cup at 4°C Liquid & 24°C Ambient)

### Safety Protections

- Low temperature and motor overload cutouts protect from cylinder over freezing.
- High pressure switch prevents compressor overheat
- Thermal overload protects from motor overheat



Selected 60 Hz. Models

50 Hz. Models



Flexible blade beater (optional)  
Higher capacity, higher overrun



ISO 9001: 2008  
Registered Firm

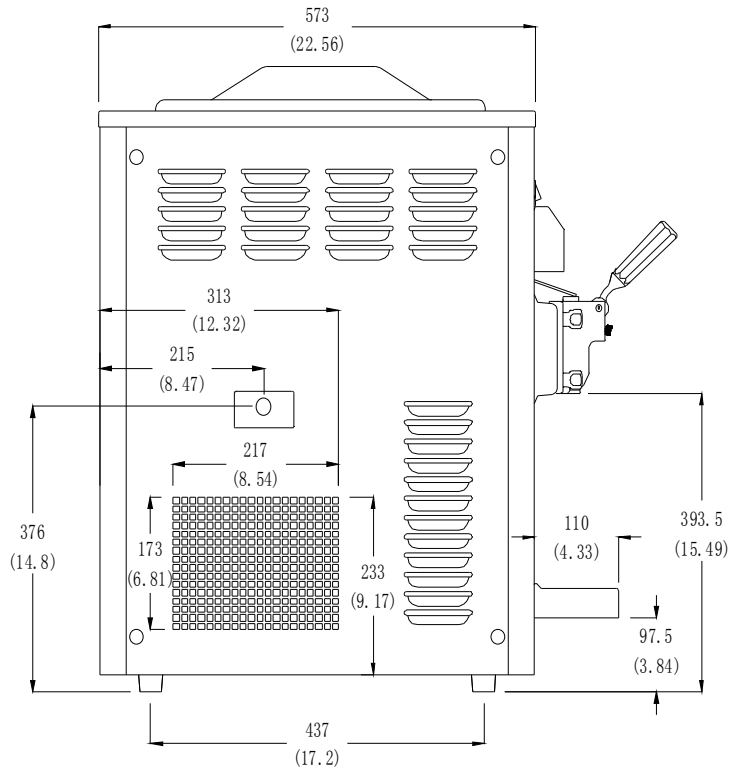
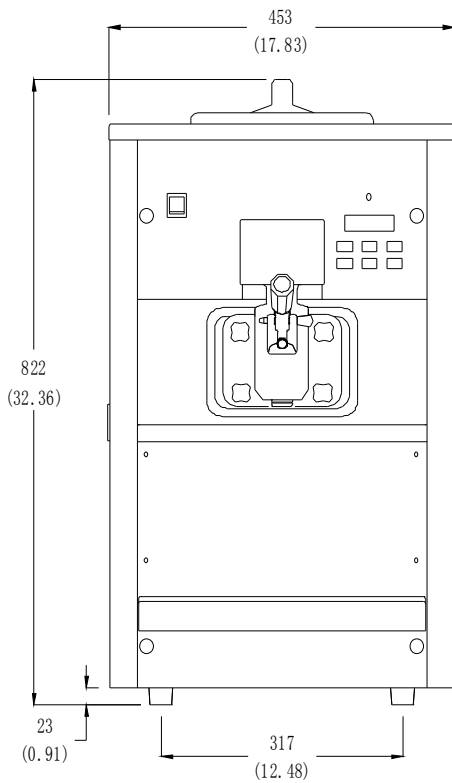

Weight	Kg/lb
Net	103 / 227
Shipping	115 / 254

<b>Packaging Volume</b>	0.36 CBM / 12.73 CBF
-------------------------	----------------------

Dimensions	Net (mm/in)	Shipping (mm/in)
Width	453 / 17.8	510 / 20.1
Depth	573 / 22.6	740 / 29.1
Height	822 / 32.4	955 / 37.6

Electrical	Maximum Fuse Size	Min. Circuit Ampacity	Poles (P) Wires(W)
220-240/50/1	16	12	3P/3W
208-230/60/1	20	15	3P/3W

*This unit may be manufactured in other electrical characteristics. Refer to the local Distributor for availability.  
(For exact electrical information, always refer to the data label of the unit.)*

**Note**  
Continuing research results in steady improvements; therefore these specifications are subject to change without notice.

## Specifications

### Electrical

One dedicated electrical connection is required. Unit shall be cord connected or permanently connected. Consult your local Spaceman distributor for available cord & receptacle specifications as per local codes.

### Motor

One, 1.25HP

### Refrigeration System

Main Compressor: One, 3650 BTU/HR, R404A

Separate Hopper Cooling Compressor:

One, 480 BTU/HR, R134A

(BTUs may vary depending on compressor used.)

### Air Cooled

Minimum clearance of 152mm (6") on both sides is required to achieve optimum performance. The rear of the unit may be placed against a wall.

### Options

- Top Air Discharge Chute (air cooled only).
- Water Cooled.
- Local language Control systems: English, French, Spanish, German, Dutch, Czech, Chinese.
- Cone dispenser